



**GULF COOPERATION COUNCIL  
INTERCONNECTION AUTHORITY**



**SNC • LAVALIN**

## **Progress Report on the GCC Electricity Grid Interconnection in the Middle East**

**by: Adnan Al-Mohaisen, GM, GCCIA  
Luc Chausse, Project Director, SNC-Lavalin  
S. Sud, V.P., SNC-Lavalin**



**Power Engineering Society, Panel Session  
Tampa, 24 – 28 June 2007**

# Progress Report on the GCC Electricity Grid System Interconnection in the Middle East

- **Project background**
- **The Interconnection Project**
- **Implementation Strategy**
- **Results of the Evaluation Process**
- **Role of the Owner's Engineer**
- **Progress of the Implementation**
- **Project schedule**
- **Other Activities of the GCCIA**
- **Conclusions**



## Project Background

- **Gulf Cooperation Council (GCC) between Kuwait, Saudi Arabia, Bahrain, Qatar, United Arab Emirates and Oman formed in 1981**
- **Recognized benefits of interconnection of electricity grids of the countries**
- **Initial study in mid-eighties**
- **Preliminary project definition study in 1990 confirmed technical, economic and financial feasibility, recommended formation of GCC Interconnection Authority**
- **GCCIA established in 1999**
- **Project technical, economic and financial feasibility updated in 2003/04**
- **Countries decided to self-finance project in 2004**
- **Project tendered and awarded in 2005**



# GCC INTERCONNECTION PROJECT – PHASE I

## Arabian Gulf States, Electrical Power Systems Interconnection



## Phase I Development Plans

- Kuwait
- Saudi Arabia-ERB
- Bahrain
- Qatar
- Year of Interconnection



2008

## Phase II Development Plans

- UAE – Formation of Emirates National Grid
- Oman – Formation of Oman Northern Grid

## Phase III Development Plans

- UAE
- Oman
- Year of Interconnection



2010



# Conceptual Diagram of the Interconnection System

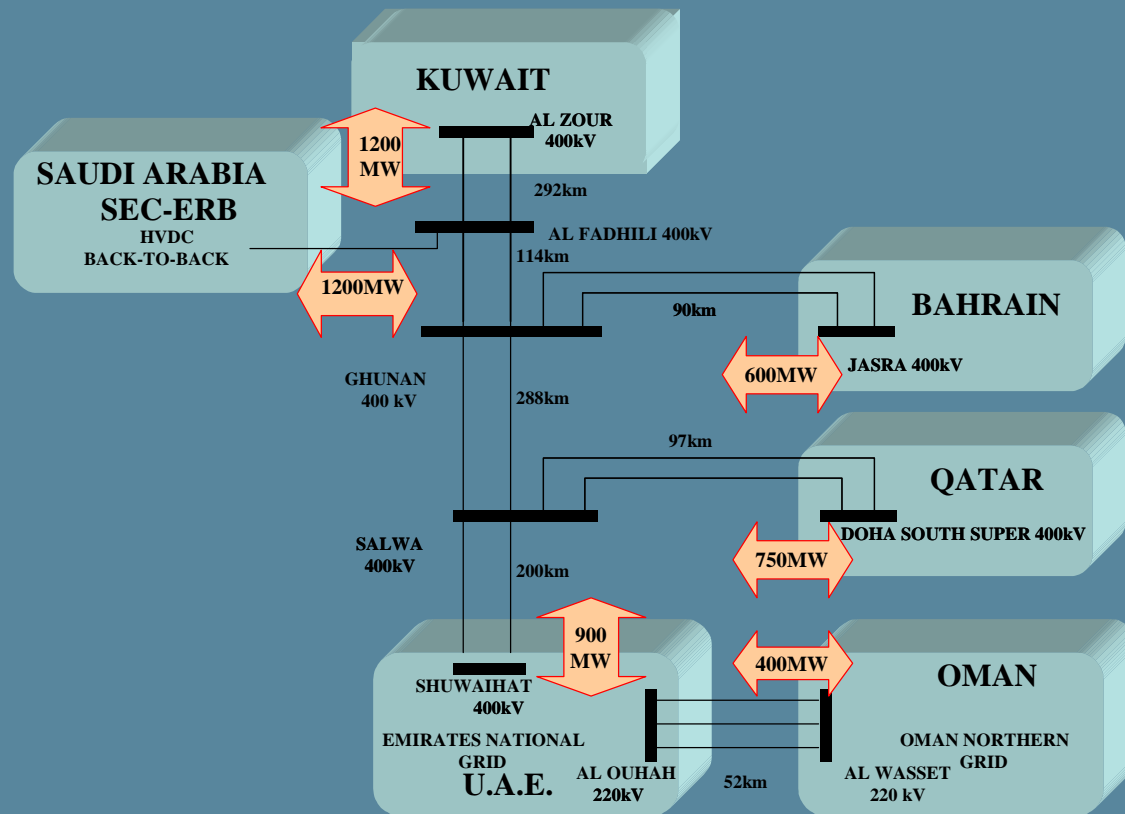

## Phase I of the Interconnection Project

- A double circuit 400 kV, 50 Hz line from Al Zour (Kuwait) to Al Fadhili (Saudi Arabia) and associated substations
- A back-to-back HVDC interconnection to the Saudi Arabia 380 kV, 60 Hz system at Fadhili
- A double circuit 400 kV, 50 Hz line from Fadhili to Ghunan (Saudi Arabia) and associated substations
- A double circuit 400 kV link, from Ghunan, comprising overhead lines and submarine and land cable link to Al Jasra (Bahrain) and associated substations
- A double circuit 400 kV, line from Ghunan to Salwa (Saudi Arabia) and associated substations
- A double circuit 400 kV, line from Salwa to Doha (Qatar) and associated substations
- A Control Centre located at Ghunan



## Phase III of the Interconnection Project

- A double circuit 400 kV, line from Salwa (Saudi Arabia) to Shuwaihat (UAE) and associated substations
- A double circuit 220 kV, line from Al Ouhah (UAE) to Al Wasset (Oman) and associated substations
- A single circuit 220 kV, line from Al Ouhah to Al Wasset and associated substations



# Simplified Single-Line Diagram of the Interconnection

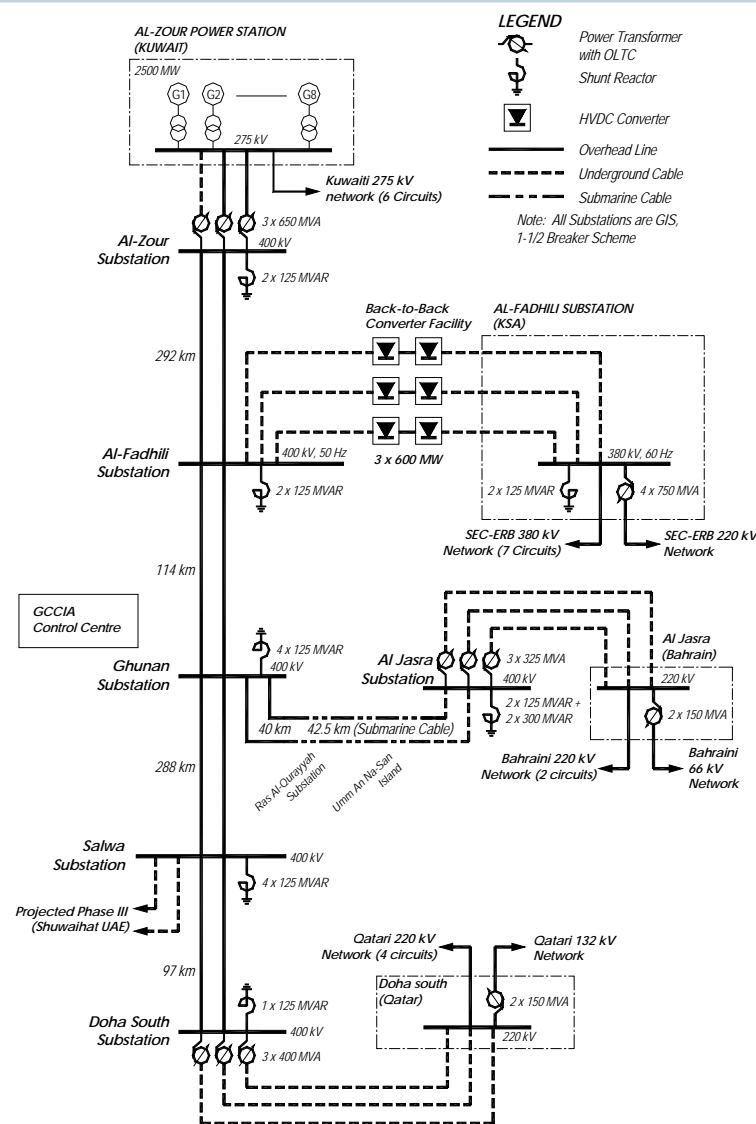

## Phase I Implementation Strategy

- For implementation purposes the project was broken down into 13 discrete EPC contract packages.
  - ✓ Six contract packages for the GIS substations
  - ✓ One contract for the back-back HVDC station
  - ✓ Four contracts for the transmission lines
  - ✓ One contract for the land & submarine cable
  - ✓ One contract for the control center (including telecommunications, control & protection)
- The contractors will work concurrently but independently from one another.
- The strategy enabled wide participation by international contractors in the shared implementation of the project.



# Implementation Strategy

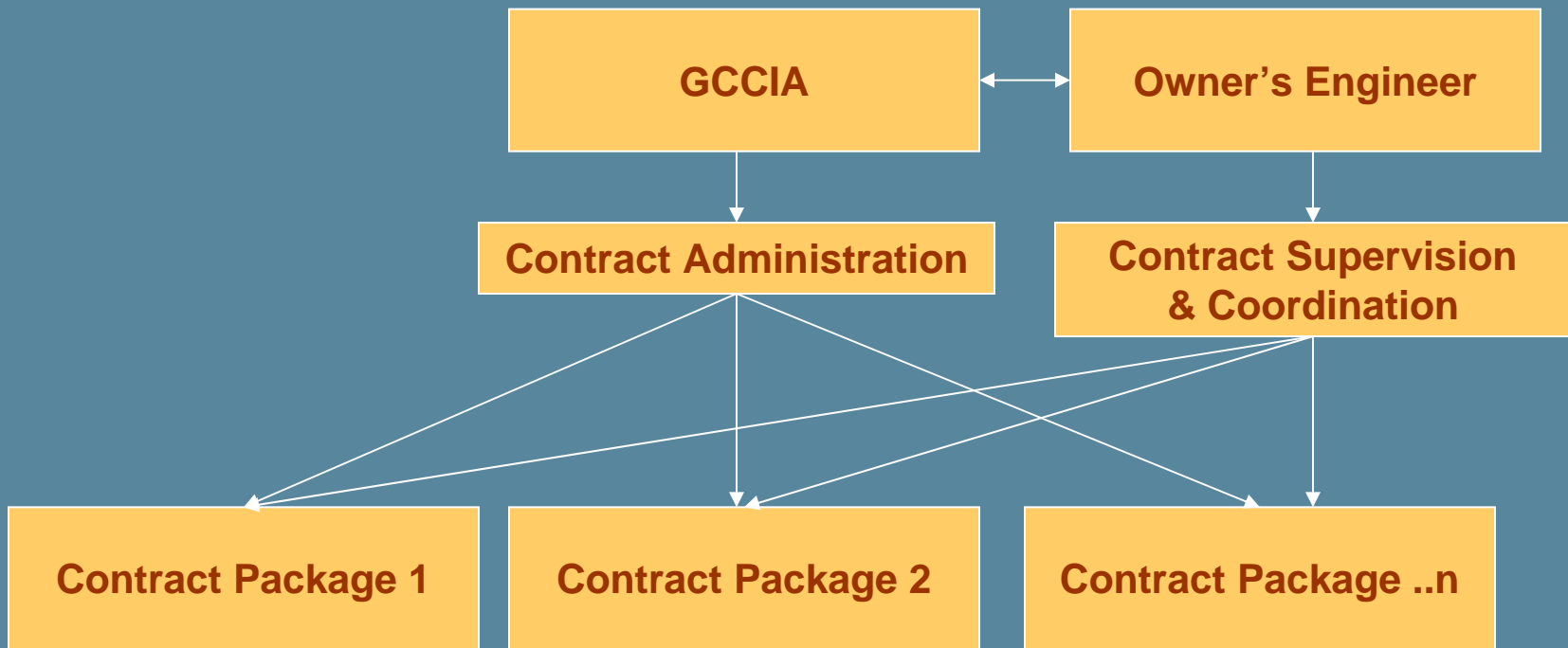

Functional Relationships



# Tendering Process

- **Invitations to Tender based on FIDIC conditions for Plant and Design Build**
- **5 Tenders received for GIS substations**
- **3 Tenders received for back-to-back HVDC station**
- **19 Tenders received for overhead transmission lines**
- **3 Tenders received for submarine and land cable**
- **4 Tenders received for control, protection & SCADA and telecommunication system**



## Results of Tender Evaluation

- **Lowest evaluated tender awarded contract**
- **Six (6) GIS substations awarded to ABB**
- **Back-to-Back HVDC station awarded to AREVA - Cogelex**
- **Two overhead transmission lines awarded to NCC**
- **Two overhead transmission lines awarded to HEC – MEEDCO**
- **Submarine & Land cable awarded to Prysmian/Nexans**
- **Control Centre, Protection & Telecommunications awarded to AREVA - Cogelex**
- **Tenders evaluated for Technical conformance and then Commercial evaluation was performed**



## Capital Cost of the Project (Phase I)

	<b>M\$US</b>
<b>GIS Substations</b>	<b>222</b>
<b>400 kV Overhead Transmission Lines</b>	<b>280</b>
<b>HVDC Back-to-Back Converter</b>	<b>206</b>
<b>Submarine and Land Cables</b>	<b>343</b>
<b>Control, Protection &amp; SCADA and Telecommunication System</b>	<b>28</b>
<b>Total</b>	<b>1079</b>



## Project Management - Complexity

- ✓ **13 different EPC contract packages with facilities in four countries : Kuwait, Saudi Arabia, Bahrain and Qatar**
- ✓ **Client, GCCIA, in Al Khobar**
- ✓ **Engineer, SNC Lavalin, based in Montreal with resident team in Al Khobar**
- ✓ **EPC Contractors design teams located in several countries plus different site offices and sourcing of equipment from around the world**
- ✓ **Information flow and design approvals is a major issue between different design and site offices**



# Project Management – Owner's Engineer

- **PM is a complex task as it involves the following critical duties:**
  - ✓ **Ensure the contract limits and interfaces are well specified**
  - ✓ **Ensure that the documentation of the contractors are consistent and cross referenced**
  - ✓ **Supervise the individual contract schedules to assure meeting the overall project schedule**
  - ✓ **Facilitate the coordination between the individual contractors and the GCC member utilities**
  - ✓ **Establish the overall control philosophy for the joint operation of the interconnected network**
  - ✓ **Supervise the testing and commissioning of the individual substations as well as the interconnected systems**
  - ✓ **Prepare weekly, monthly and quarterly progress reports**



## Progress of Implementation

- ✓ Design review of the GIS substations is well advanced and issues such as interfacing with existing substations and fitting into available space were addressed
- ✓ Work is progressing on the detailed design studies for the HVDC converters
- ✓ Design review is well advanced for the Transmission lines. Because of the environmental pollution it was decided to coat the insulators with silicone. The concrete mix for the foundations had to take into account the high salt content in the soil.
- ✓ A detailed survey of the submarine and land cable routes has been completed.
- ✓ Design review is underway for the Control Centre and the protection and telecommunication system



## Add Pictures from sites



## Project Schedule

<b>Update Technical and Economic Feasibility</b>	<b>2003 / 2004</b>
<b>Approval of Project Financing</b>	<b>May 2004</b>
<b>Issue of Tender Documents</b>	<b>February 2005</b>
<b>Tenders Received</b>	<b>June 2005</b>
<b>Tenders Evaluated and Recommendation for Award</b>	<b>September 2005</b>
<b>Contracts Awarded</b>	<b>November 2005</b>
<b>Project Operation</b>	<b>Early 2009</b>



## Other GCCIA Activities

- ✓ **Define the organization of the GCCIA and prepare the Authority for the Operations Phase**
- ✓ **Develop the legal framework to govern the Ownership and Operations of the Interconnection**
- ✓ **Develop the Interconnection Agreements**



# Conclusions

- **Project under-study since mid-eighties**
- **Agreement and participation required by six GCC countries**
- **Principal Issues that had to be resolved**
  - ✓ **Demonstration of feasibility**
  - ✓ **Agreement between countries**
  - ✓ **Creation of the GCC Interconnection Authority**
  - ✓ **Agreement on cost sharing and financing**
- **Implementation Strategy Adopted**
- **Project divided into work packages to ensure International competitive bidding**
- **Project is now under implementation**
- **Design review and approval process is underway**
- **Site work has been started**



# Approximate Route and Layout of the GCC Interconnection

